

# TRINITY CONTAINERS UNDERGROUND TANKS

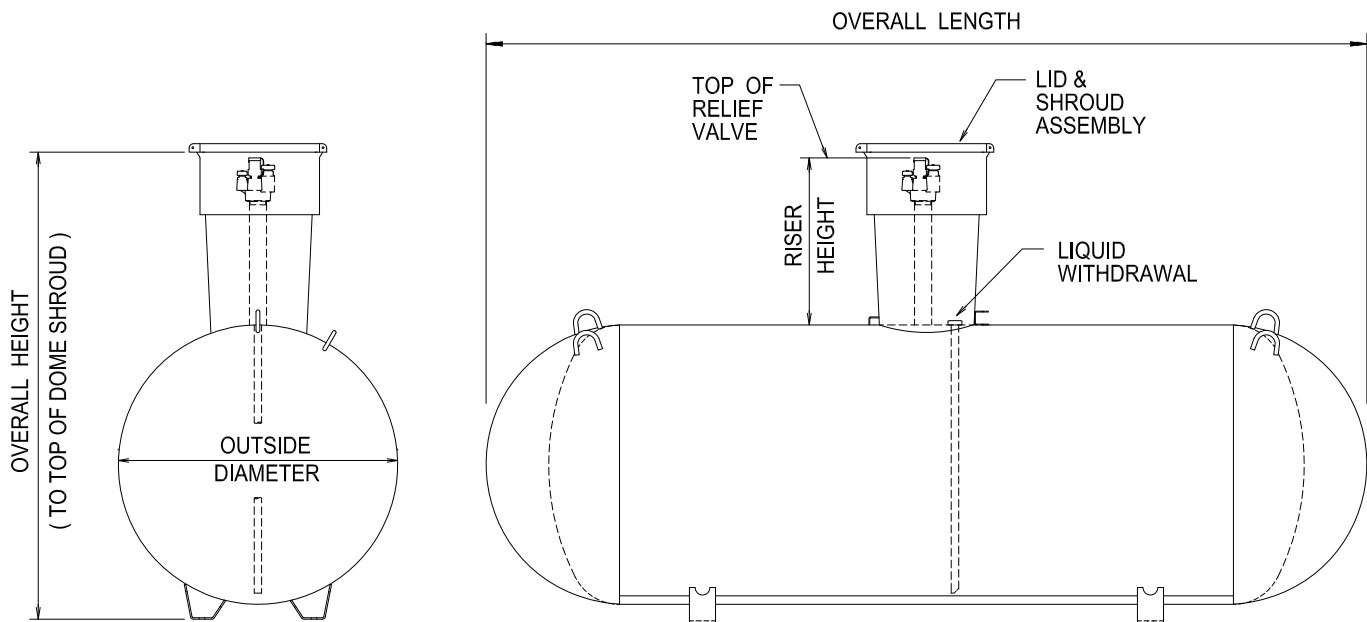

## General Specifications

Conforms to the latest edition and addenda of the ASME, Section VIII, Division 1. Complies with NFPA 58.

Container pressure rated at 250 psig from -20° F. to 125° F. All tanks may be be evacuated to a full (14.7 psi) vacuum.

Vessel finish: Coated with TGIC red powder.

Applicable federal, state or local regulations may contain specific requirements for protective coatings and cathodic protection. The purchaser and installer are responsible for compliance with all federal, state, or local regulations. Including proper purging for first fill per NGPA 133-89 (a)

### UNDERGROUND VESSEL DIMENSIONAL INFORMATION

All vessels dimensions are approximate

WATER CAPACITY	OUTSIDE DIAMETER	HEAD TYPE	OVERALL LENGTH	OVERALL HEIGHT Riser Height		WEIGHT (APPROX.)	QUANTITY	
				14"	28"		FULL LOAD	PER STACK
120 wg. 454.2 L	24" 609.6 mm	Ellip	5' - 5 7/8" 1673.2 mm	3' - 4 5/8" 1031.9 mm	4' - 6 3/4" 1390.7 mm	260 lbs. 117.9 kg.	72	9
250 wg. 946.3 L	31.5" 800.1 mm	Hemi	7' - 2 1/2" 2197.1 mm	4' - 0 5/8" 1235.1 mm	5' - 2 1/16" 1576.4 mm	490 lbs. 222.3 kg.	49	7
320 wg. 1211.2 L	31.5" 800.1 mm	Hemi	8' - 11 3/4" 2736.9 mm	4' - 0 5/8" 1235.1 mm	5' - 2 1/16" 1576.4 mm	610 lbs. 276.7 kg.	35	7
500 wg. 1892.5 L	37.42" 950.5 mm	Hemi	9' - 10" 2997.2 mm	4' - 6 1/2" 1384.3 mm	5' - 8 1/8" 1730.4 mm	920 lbs. 417.3 kg	25	5
1000 wg. 3785.0 L	40.96" 1040.4 mm	Hemi	15' - 10 7/8" 4848.2 mm	4' - 9 1/2" 1460.5 mm	6' - 0" 1730.4mm	1760 lbs. 798.3 kg	12	5
1465 wg. 5545.0 L	46.77" 1188 mm	Ellip	17' - 6 7/8" 5356.2 mm	5' - 3 7/8" 1722.4 mm	6' - 5" 1955.3 mm	2830 lbs. 1283.7 kg	9	3
2000 wg. 7570.0 L	46.77" 1184 mm	Ellip	23' - 9" 7239 mm	5' - 3 7/8" 1722.4 mm	6' - 5" 1955.3 mm	3510 lbs. 1592.1 kg	6	3